

PROPORTIONAL SOLENOID VALVE (PSV™)

400 SERIES, 2 WAY NORMALLY CLOSED PROPORTIONAL VALVE FOR FLUID AND GAS MEDIA (PATENTED)

COMPONENT FEATURES

- Inert gases and liquids compatible with stainless steel, aluminum, EPDM and nylon materials
- Metallic ball or special elastomeric seal available
- Fast response time - 20 msec typical
- Maximum flow rate: 0-150 slpm @ 40 psid [2.76 bar]
- ESEOD 0.100" max. [2.54 mm]
- Maximum input pressure: 60 psig [4.14 bar]
(Contact factory for higher pressures)
- Turn-down ratios in excess of 1,000:1
- Manifold mounted design allows maximum flexibility
- Robust design with computerized calibration insures reliability & repeatability for millions of cycles

TYPICAL FLOW CURVE

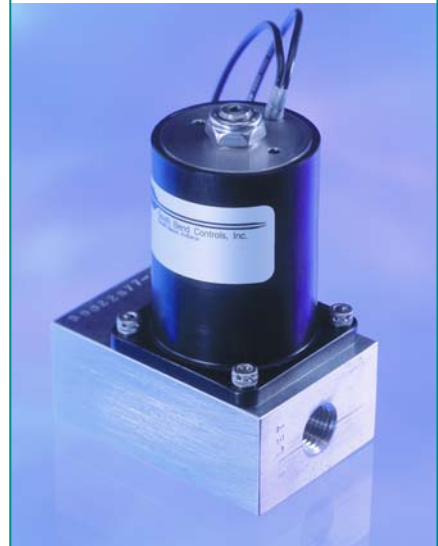
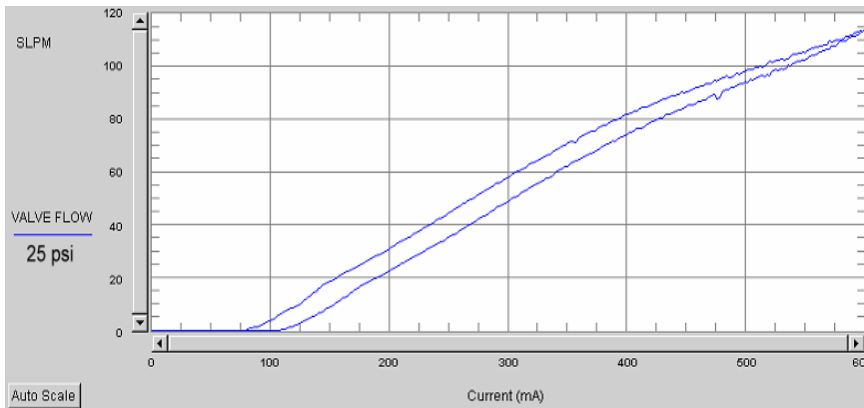

PSV Valve with test manifold

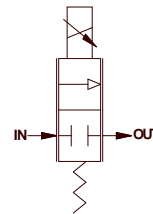

FLOW SCHEMATIC

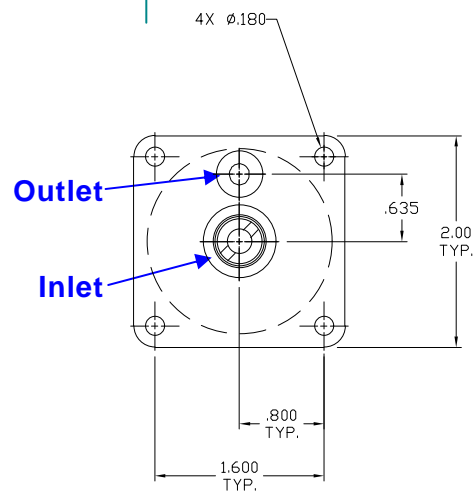
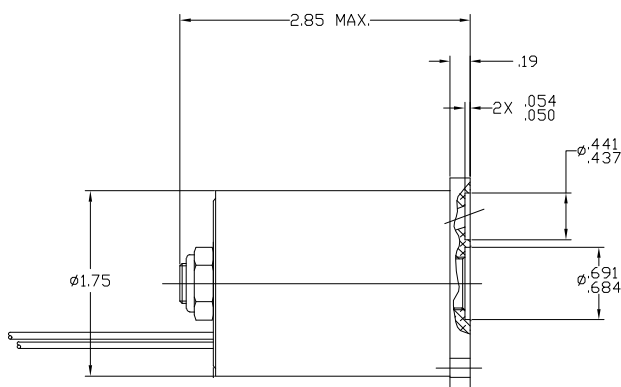

1237 NORTHSIDE BOULEVARD · SOUTH BEND, IN 46615
TEL+1.574.234.3157 · FAX+1.574.234.3948 · WEB www.sbcontrols.com

BULLETIN PV-222

PROPORTIONAL SOLENOID VALVE (PSV™) TECHNOLOGY

The 400 Series' current-driven, proportional DC solenoid driver responds to either analog or digital (1 kHz pulse-width-modulated) signals. Input current is translated into a specific displacement with infinite resolution. The displacement is applied to a metering orifice with resulting flow control.

- Linear & Proportional flow control in OEM devices such as ventilators, gaseous fuel systems, etc.
- Utilizes suspended armature design with no sliding friction to minimize hysteresis
- Available with hard or soft seats depending upon the system requirements
- Based upon proven technologies with high accuracy and long term repeatability
- Factory calibrated to meet your exact application requirements

This type of valve can be used with liquid or gaseous media in any system which requires proportional flow control with high accuracy and repeatability. Common use is in life or health support systems where air and oxygen or anesthetic gases must be independently controlled and blended in varying ratios to suit the patients' needs. Other uses include hydrogen metering for fuel cells and metering vacuum in critical processes.

VALVE PART NUMBER SYSTEM

