

PROPORTIONAL GAS METERING VALVE

2-WAY NORMALLY CLOSED PROPORTIONAL VALVE
FOR GASEOUS FLOW CONTROL (PATENTED)

COMPONENT FEATURES

- Compatible with low pressure gas: Air, Oxygen, Heliox & Anesthesia
- Flow rates up to 200 slpm – 25 psig [2.7 bar] supply (ESEOD of 0.20")
- Flow range tuned to the pressure and individual system requirements
- Poppet design provides inlet and outlet pressure balancing
- Turn-down ratios in excess of 1,000:1
- Metallic poppet & seat provide long reliable life with crisp lift-off
- Fast response time (20 msec typical)
- Robust design with computerized calibration insures reliability & repeatability for 100's of millions of cycles
- Fully encapsulated coil – durability that comes with a reduced cost



PROPORTIONAL GAS METERING VALVE

TYPICAL FLOW CURVE

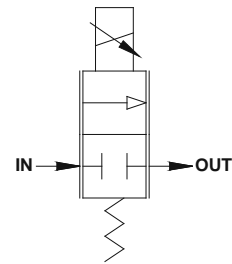
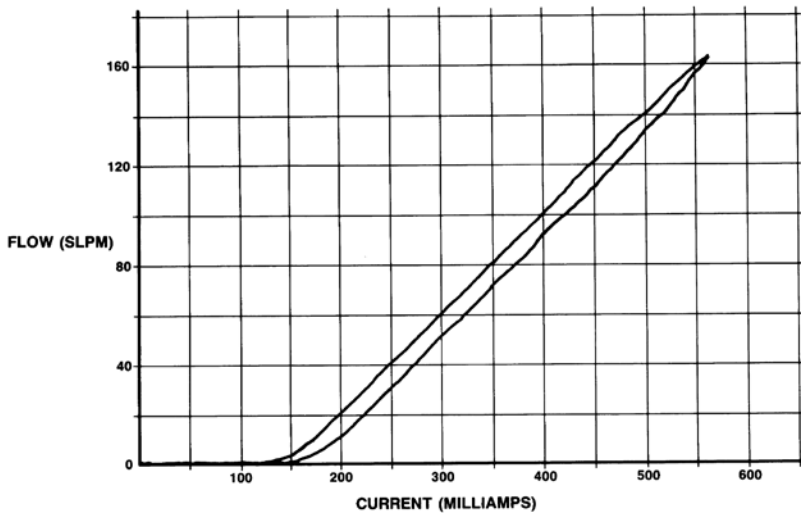

FLOW SCHEMATIC

TYPICAL VENTILATOR, INSPIRATION FLOW

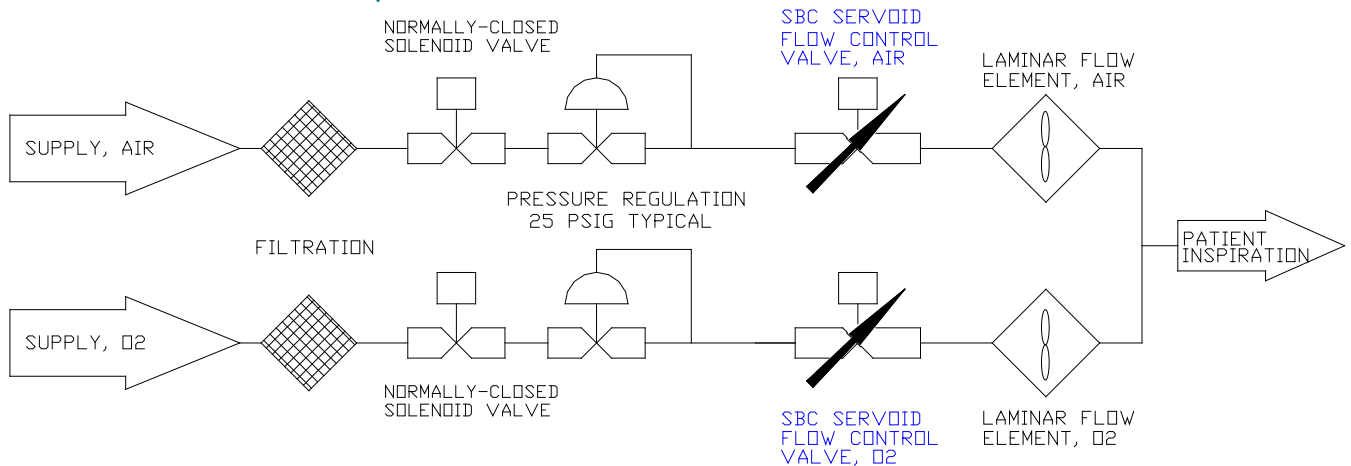

SOUTH BEND CONTROLS

1237 NORTHSIDE BOULEVARD • SOUTH BEND, IN 46615
TEL+1.574.234.3157 • FAX+1.574.234.3948 • WEB WWW.SBCONROLS.COM

BULLETIN PV-221

TECH DATA

PROPORTIONAL METERING VALVE TECHNOLOGY

The Gas Metering Valve's current-driven, proportional DC solenoid driver responds to either analog or digital (1 kHz pulse-width-modulated) signals. Input current (0 to 600 milliamps) is translated into a specific displacement with infinite resolution. The displacement is applied to a metering orifice with resulting flow control. Multiple coil resistances are available to accommodate different voltage power supplies.

- Linear & Proportional flow control in: Ventilators, Anesthesia Equipment & Sleep Apnea devices, etc.
- Utilizes suspended armature design with no sliding friction to minimize hysteresis.
- Metallic poppet & seat combination provide consistent lift-off and repeatable low flow control.
- Proven technologies with high accuracy and long term reliability – 100's of millions of cycles.

This type of valve can be used with gaseous media in any system which requires proportional flow control with high accuracy and repeatability. Typical uses include life & health support systems where air and oxygen or anesthetic gases must be independently controlled and blended in varying ratios to suit the patients' respiratory needs. Additional applications have been in metering of Natural Gas for small turbine power generation systems, hydrogen metering for fuel cells and metering vacuum in critical processes.

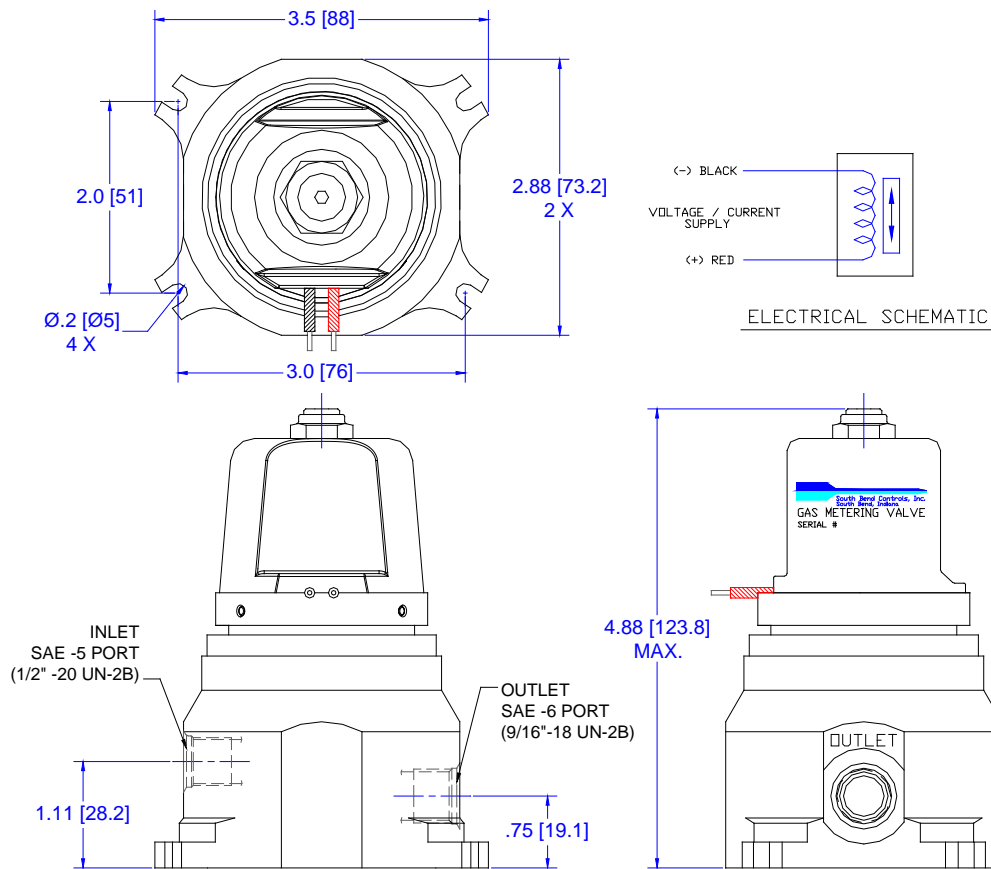

SOUTH BEND CONTROLS

1237 NORTHSIDE BOULEVARD • SOUTH BEND, IN 46615
 TEL+1.574.234.3157 • FAX+1.574.234.3948 • WEB WWW.SBCONROLS.COM

BULLETIN PV-221

PRINTED IN USA
 ©SBC 2009