

PROPORTIONAL AIR CONTROL VALVE

PROPORTIONAL FLOW CONTROL VALVE WITH DELTA-P PRESSURE REGULATION

COMPONENT FEATURES

- Aerospace qualified in defense applications
- Single-stage metering for fast response
- Compensates for variations in inlet & outlet pressure
- Continuous-duty proportional Servoid™ driver
- Each unit is tested under high, low and ambient temperatures
- Configured specifically to the requirements of each system
- Porting, manifold, and mounting flexibility

ACTUAL PERFORMANCE CURVE

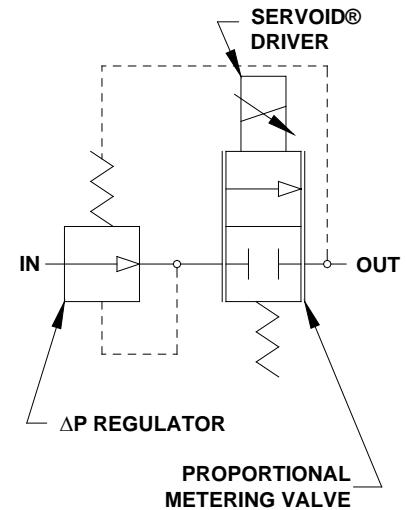
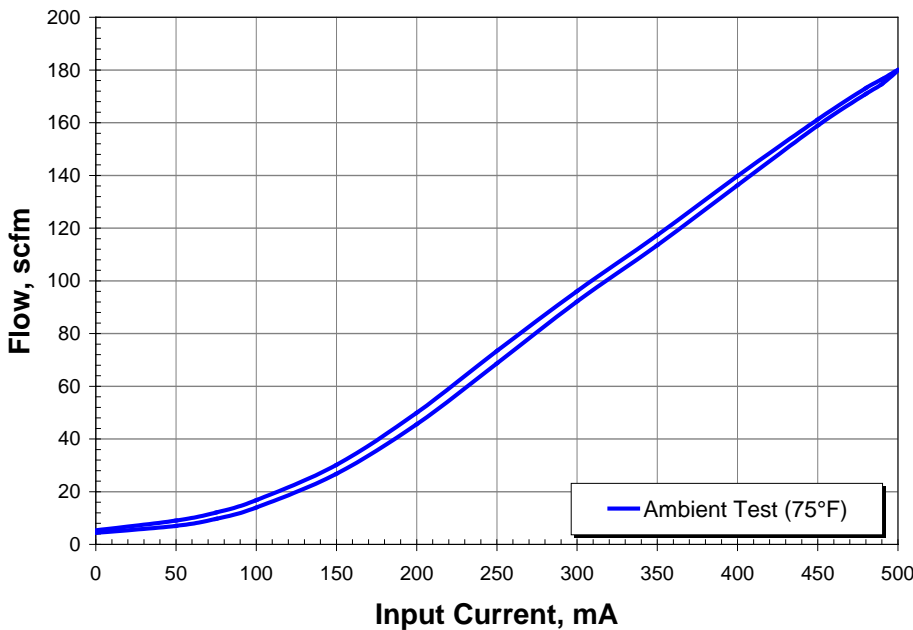

FLOW SCHEMATIC

SPECIFICATIONS

- 1.0 Valve Type: Proportional, Pressure Compensated Flow Control
- 2.0 Media: Air
- 3.0 Pressure
- 3.1 Operating: 1,020 to 1700 +/- 15 psig
 - 3.2 Proof: 3,000 psig
 - 3.3 Burst: 4,250 psig
- 4.0 Internal Regulation: 300 psi differential
- 5.0 Performance
- 5.1 Calibration: Per ATP Requirements
- 6.0 Temperature
- 6.1 Ambient: -40°F to +300°F
 - 6.2 Media: -190°F to +160°F

- 7.0 Maximum Flow: 180 scfm (85 slps) at 300 psid*
*At approx. 1000 psi backpressure
- 8.0 Minimum Flow: ~7 scfm @ 1550 psig Inlet
200 psig Outlet
- 9.0 Electrical
- 9.1 Coil Current: 0 to 500 milliamps
 - 9.2 Coil Resistance: 20.5 Ω @ 77°F +/- 3 Ohm
 - 9.3 Insulation Resistance: 1x10⁸ Ω minimum
- 10.0 External Leakage: None
- 11.0 Weight: 4.90 lbm [2.67 kg]

SOUTH BEND CONTROLS

1237 NORTHSIDE BOULEVARD • SOUTH BEND, IN 46615
TEL+1.574.234.3157 • FAX+1.574.234.3948 • WEB WWW.SBCONTROLS.COM

BULLETIN PV-212

PROPORTIONAL AIR CONTROL VALVE TECHNOLOGY

- The Proportional Air Control Valve is comprised of three primary components, the Servoid®-Driver, a Proportional Metering Valve and the Delta-P Regulator.
- The Servoid® Driver, is a current-driven, proportional DC solenoid which responds to either analog or digital (1 kHz pulse width modulated) signals. Input current (0 to 500 mA) is translated into a specific displacement with infinite resolution. The displacement is applied to a precision metering spool with resulting flow control. Servoid drivers also include suspended armature construction with no sliding elements. This provides low hysteresis and long component life.
- The Proportional Metering Valve is a proprietary pressure balanced configuration providing extremely high flow capacity in a single stage.
- The Delta-P Regulator is a pressure reducing differential pressure regulator that maintains a constant pressure differential across the metering orifice. This pressure differential insures a constant net flow even while supply and downstream pressures vary, as is common with turbine engines.

This valve and a corresponding fuel metering valve control the flow and ratio of air & fuel to airborne turbine auxiliary power units (Reference PV-213). These systems include complex feedback to account for a wide range of startup parameters. Servoid valves also function well under open-loop conditions with high repeatability. This valve can be used anywhere highly repeatable flow control of gaseous media is a requirement and similar valves are also available for control of liquids such as fuels, coolant, and solvents.

