

# HIGH PRESSURE CHECK VALVE

BUBBLE-TIGHT SEALING UNDER REVERSE FLOW CONDITIONS

## COMPONENT FEATURES

- Qualified for Space, Aircraft & Rotorcraft applications
- Bubble tight for high pressure pneumatic systems
- Low cracking pressure & high flow capacity
- High strength, corrosion resistance materials
- Elastomers selected to meet specific application requirements
- Porting & mounting flexibility including manifold insertion
- Configurations engineered to your specific requirements

## SPECIFICATIONS

- 1.0 Valve Type: Check Valve  
2.0 Media: All Common Gases – liquid configurations available \*  
3.0 Pressure  
    3.1 Operating: 3,000 psig [208 bar]  
    3.2 Proof: 4,500 psig [311 bar]  
    3.3 Burst: 7,500 psig [518 bar] - min  
    3.4 Crack: 10 to 15 psi [0.7 to 1.0 bar] differential  
4.0 Temperature  
    4.1 Ambient: -65°F to +300°F [-54°C to 149°C]  
    4.2 Media: -40°F to +160°F [-40°C to 71°C]  
5.0 Leakage: Bubble-tight @ 3,000 psi [208 bar]  
6.0 Weight: 0.11 lb [50 grams] - max  
7.0 Materials: Stainless Steels (304L, 17-4 PH, 303)  
Elastomers – Application Specific



**\*PLEASE CONTACT SBC  
ENGINEERING FOR  
OTHER CHECK VALVE  
APPLICATIONS.**

HIGH PRESSURE CHECK VALVE

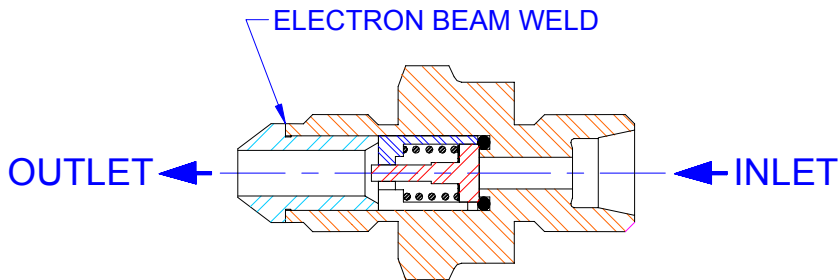

## FLOW SCHEMATIC

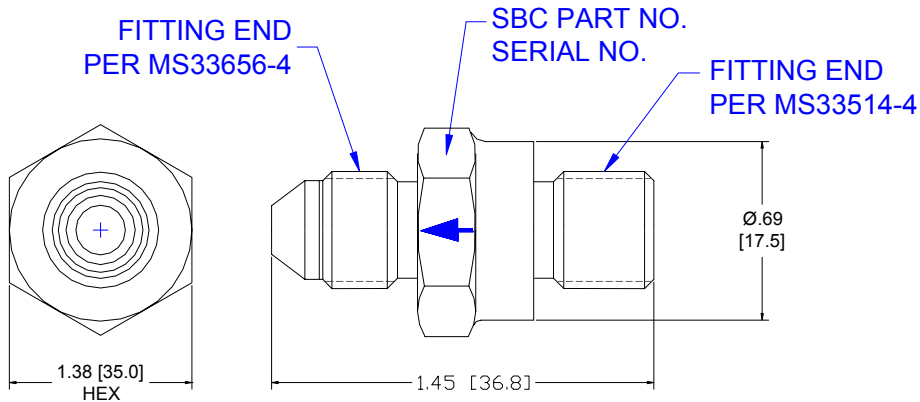
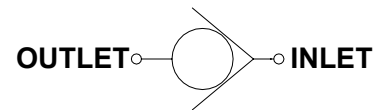

*South Bend Controls, Inc.*

1237 NORTHSIDE BOULEVARD • SOUTH BEND, IN 46615

TEL+1.574.234.3157 • FAX+1.574.234.3948 • WEB [WWW.SBCONROLS.COM](http://WWW.SBCONROLS.COM)

**BULLETIN AV-507**

TECH DATA

## HIGH PRESSURE CHECK VALVE

**What is it?** This is a poppet-style check valve designed for used in high pressure pneumatic systems. This check valve has been engineered for gases such as nitrogen, argon or helium, with qualified configurations also available for liquids such as sea water, hydraulic fluids & petroleum fuels.

**How does it work?** The spring-loaded poppet is preloaded against an elastomer seat for bubble-tight sealing at differential pressures of 10-15 psi. This closed position incorporates a positive stop to prevent over compression of the seat. When differential pressure exceeds this level, pressure forces overcome the spring preload and the poppet translates to the open position. Flow occurs from the inlet to the outlet of the valve as long as the minimum differential pressure is maintained. If the flow attempts to change direction, the flow force and spring preload translate the poppet back against the elastomer seat and reverse flow is stopped. The elastomer seat is maintained out of the flow path to insure positive sealing throughout the entire performance envelope. Each valve is individually tested for flow, cracking pressure and leakage as part of an approved acceptance test procedure.

**How is it used?** This valve insures that flow occurs in a single direction only. Aircraft & defense systems rely on this to prevent damage caused by reverse flow conditions or to minimize loss of pressure in the event of an upstream failure. SBC will engineer a configuration of this valve to meet your specific application requirements.

**Related products:** see tech data bulletins AV-503 for Fill/Vent Valves, AV-501 for Pressure Regulators and AV-505 for Pneumatic Solenoid Valves.

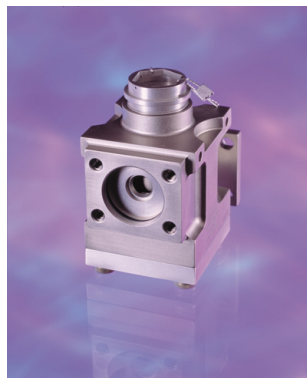

*South Bend Controls, Inc.*

1237 NORTHSIDE BOULEVARD • SOUTH BEND, IN 46615  
TEL+1.574.234.3157 • FAX+1.574.234.3948 • WEB [WWW.SBCONROLS.COM](http://WWW.SBCONROLS.COM)

**BULLETIN AV-507**

PRINTED IN USA  
JPG 1006 ©SBC 2006